

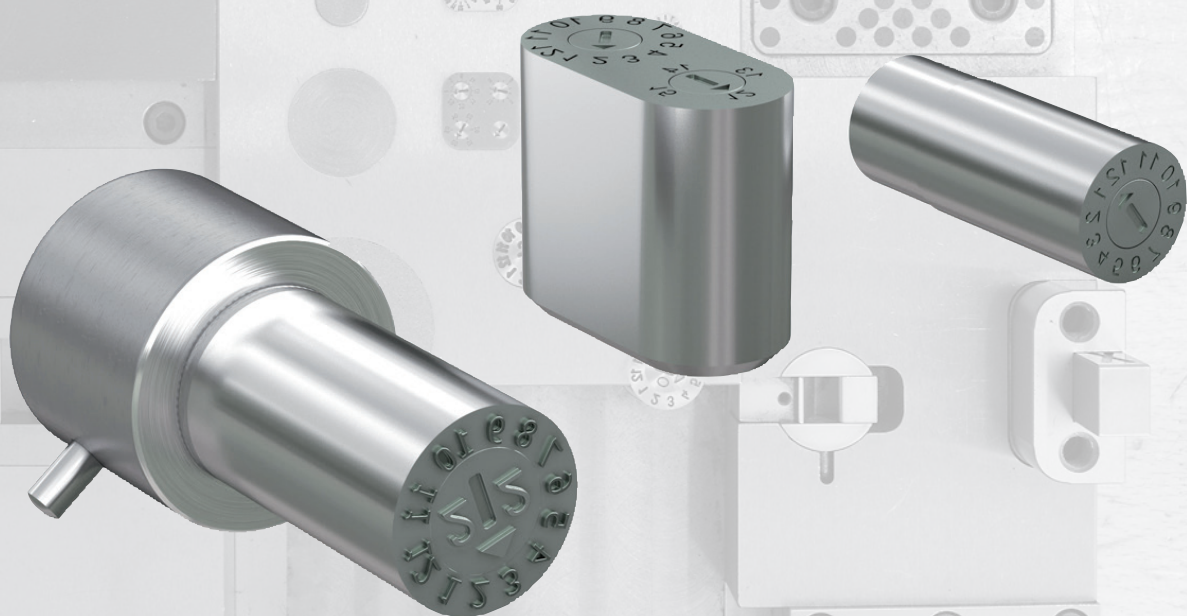









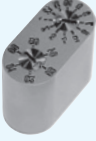
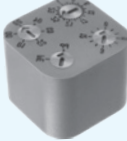
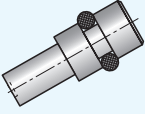

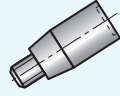
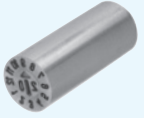
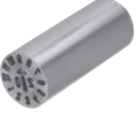



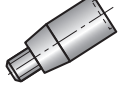
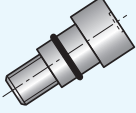
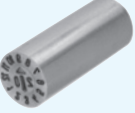
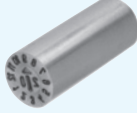
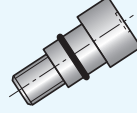

DATUMSSTEMPEL, PRÄGESTEMPEL
DATE INSERTS, EMBOSSING STAMPS
DATEURS, TAMPONS DATEUR AVEC
GRAVURE EN RELIEF



STRACK®

NORMALIEN

2

					
Z5147-9 2.88	Z5148-18 2.88	Z5150-3 2.89	Z5155-6 2.89	Z5156-3 2.90	Z5157-5 2.90
					
Z5158-5 2.90	Z5159-3 2.90	Z5156-4 2.91	Z5157-8 2.91	Z5158-8 2.91	Z5159-4 2.91
					
Z5156-3,5 2.92	Z5157-3,5 2.92	Z5158-3,5 2.92	Z5159-3,5 2.92	Z5163 2.94	Z5178 2.94
					
Z5160 2.94	Z5174-6 2.95	Z5177-10 2.95	Z5205 2.96	Z5201 2.97	Z5202 2.98
					
Z5200 2.98	Z5204 2.98	SN5270 2.99			

2

Multimarker

Multimarkers

Poinçons de marquage multiple

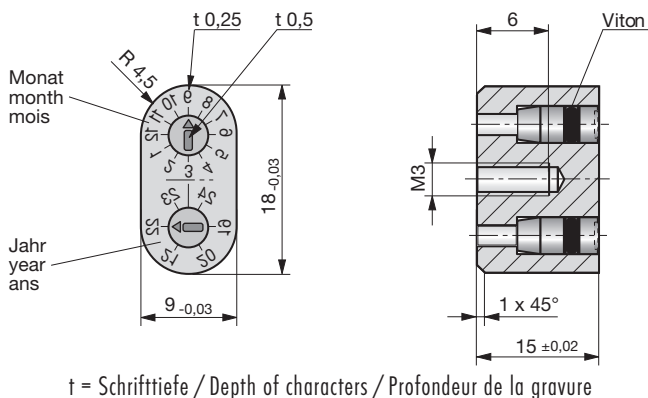

Z5147-9

Mat.: 1.2343
~50HRC



Z5147-9



t = Schrifttiefe / Depth of characters / Profondeur de la gravure

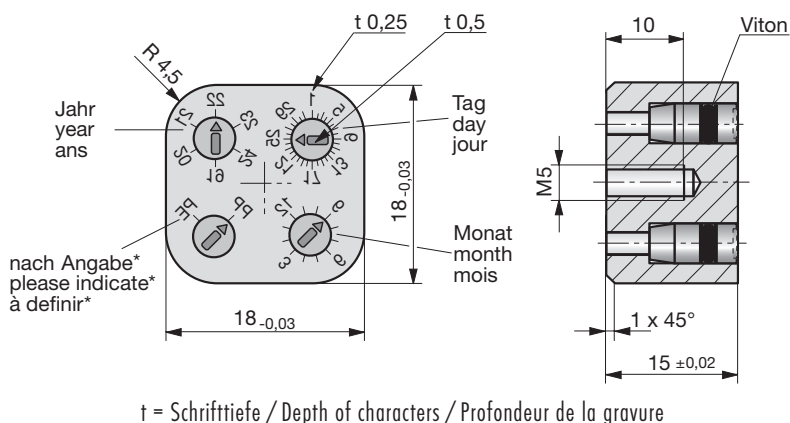

Z5148-18

Mat.: 1.2343
~50HRC



Z5148-18-Mat



t = Schrifttiefe / Depth of characters / Profondeur de la gravure

Material	Material	Materiaux
Kunststoff-Kurzzeichen	Plastic-symbol for basic polymers	Sigle des matieres plastiques
*Bitte Material-Kurzzeichen angeben.	*Please indicate material abbreviation.	*Merci d'indiquer le sigle de la matière,
4 Kurzzeichen max. möglich.	4 abbreviations max. possible.	4 caractères maximum.

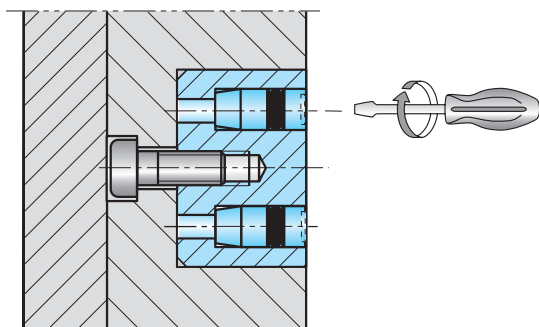

Datumsstempel

Date inserts

Dateurs

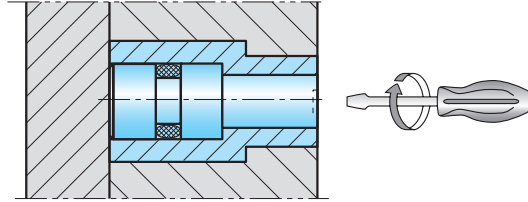

2

t = Schrifttiefe / Depth of characters / Profondeur de la gravure

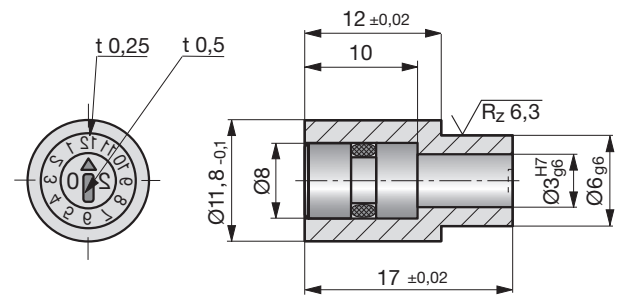
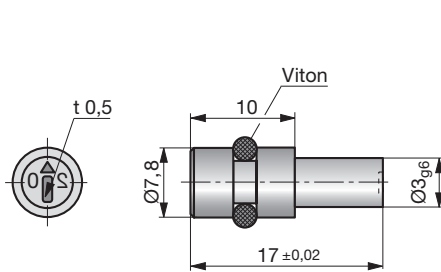

Z5150-3-

Mat.: 1.2842
~60HRC

Z5155-6-

Mat.: 1.2842
~60HRC



Z5150-3-a



Z5155-6-a



a

laufendes Jahr / current year / année courante

a

laufendes Jahr / current year / année courante

2

Datumsstempel

Date inserts

Dateurs

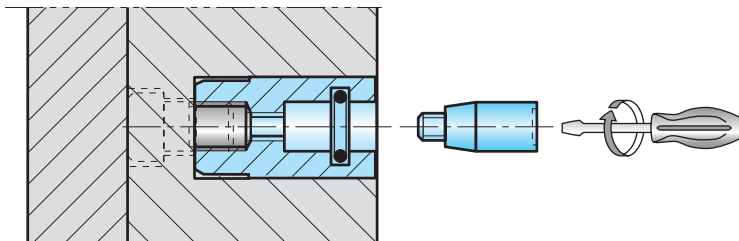
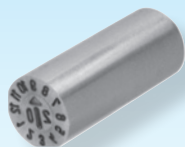

t = Schrifttiefe / Depth of characters / Profondeur de la gravure

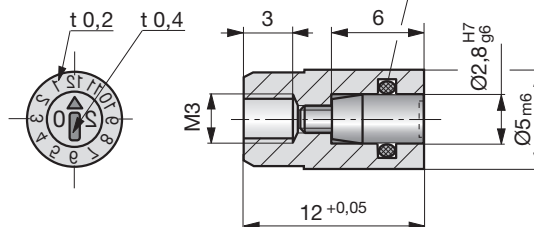
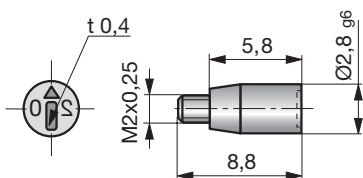

Z5156-3-

Mat.: 1.2842
~60HRC

Z5157-5-

Mat.: 1.2842
~60HRC



Z5156-3-a



Z5157-5-a



a

laufendes Jahr / current year / année courante

a

laufendes Jahr / current year / année courante

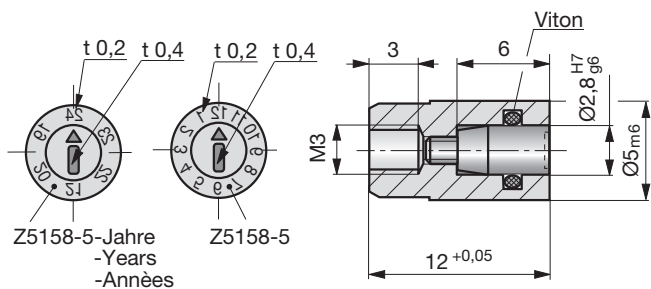

Z5158-5-Jahre
-Years
-Années

Z5158-5

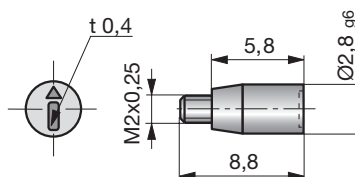

Z5158-5 Z5158-5-

Mat.: 1.2842
~60HRC

Z5159-3

Mat.: 1.2842
~60HRC



Z5158-5
Z5158-5-Jahre



Z5159-3



Z5158-5

Z5158-5-Jahre/Years/Années

-

18 - 23

-

19 - 24

Datumsstempel

Date inserts

Dateurs

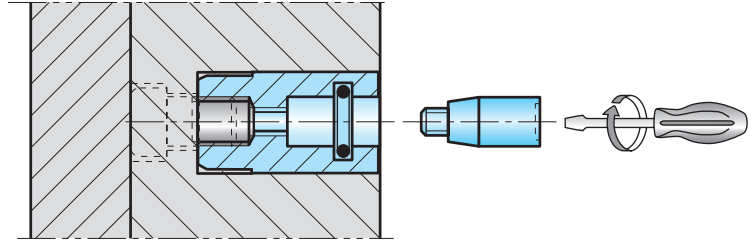
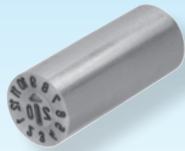

t = Schrifttiefe / Depth of characters / Profondeur de la gravure

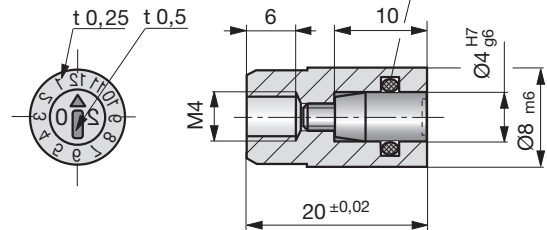
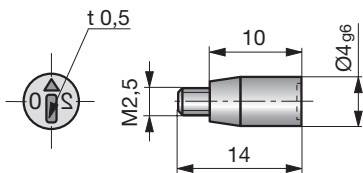

Z5156-4-

Mat.: 1.2842
~60HRC



Z5156-4-a



Z5157-8-

Mat.: 1.2842
~60HRC



Z5157-8-a



a

laufendes Jahr / current year / année courante

a

laufendes Jahr / current year / année courante

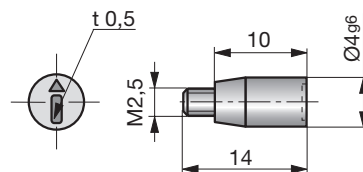
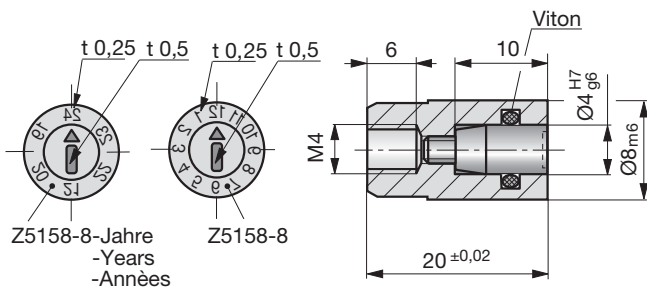

Z5158-8 Z5158-8-

Mat.: 1.2842
~60HRC

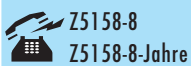

Z5158-8
Z5158-8-Jahre



Z5159-4

Mat.: 1.2842
~60HRC



Z5159-4



Z5158-8

Z5158-8-Jahre/Years/Années

-

18 - 23

-

19 - 24

2

Datumsstempel

Date inserts

Dateurs

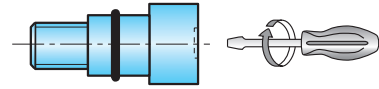
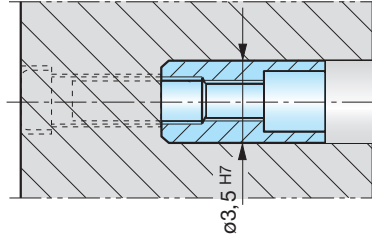
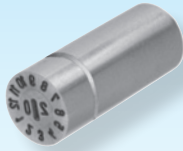

Markierung in Werkzeugkontur einbringen
Insert marking in the tool contour
Poser marque dans le contour de l'outil

t = Schrifttiefe / Depth of characters / Profondeur de la gravure

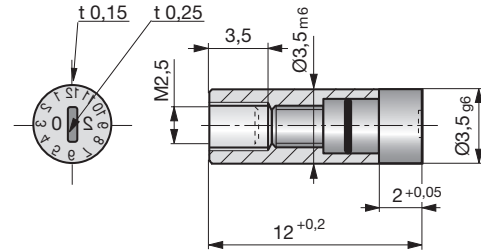
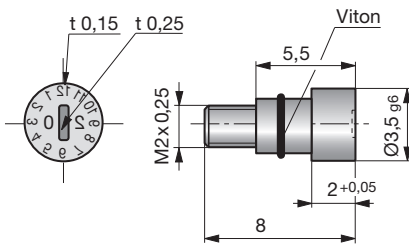
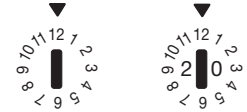

Z5156-3,5-

Mat.: 1.2162
~56HRC

Z5157-3,5-

Mat.: 1.2162
~56HRC



Z5156-3,5-a



Z5157-3,5-a



a

laufendes Jahr / current year / année courante

a

laufendes Jahr / current year / année courante

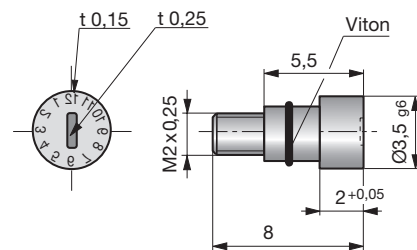
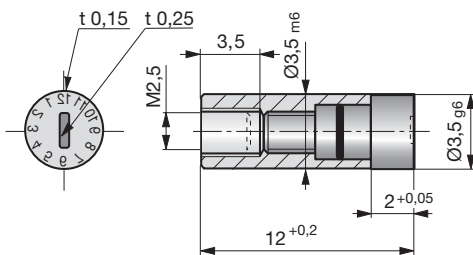

Z5158-3,5

Mat.: 1.2162
~56HRC

Z5159-3,5

Mat.: 1.2162
~56HRC

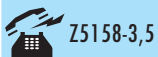

Z5158-3,5



Z5159-3,5



Datumsstempel

Date inserts

Dateurs

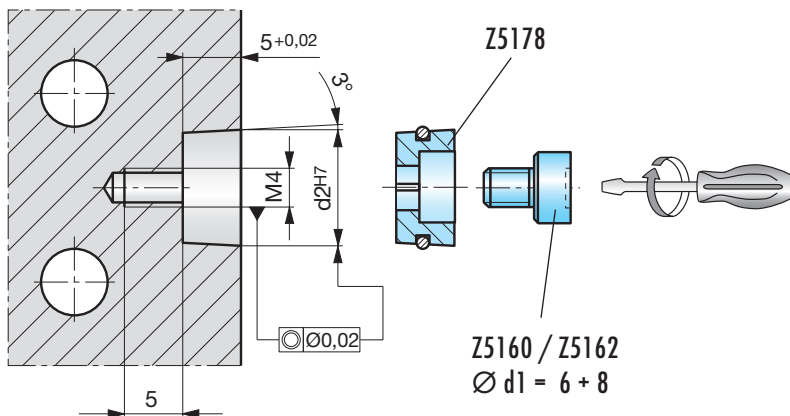

t = Schrifttiefe / Depth of characters / Profondeur de la gravure

MONTAGEANWEISUNG

FITTING INSTRUCTIONS

MONTAGE

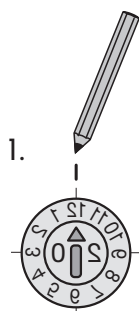

1. - Prägestempel komplett montieren,
- Pfeilrichtung markieren
2. - Innenteil Z5201/ Z5208 ausschrauben,
- Hülse Z5202 zur Markierung in Position drehen
3. - Innenteil Z5201/ Z5208 einschrauben,
- Position überprüfen

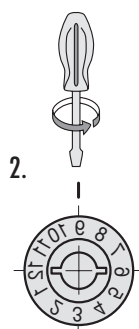

1. - Fully mount embossing stamp,
- Mark arrow direction
2. - Unscrew inner part Z5201/ Z5208,
- Rotate sleeve Z5202 into position for marking
3. - Screw in inner part Z5201/ Z5208,
- Check position



1. - Monter l'ensemble dateur,
- Repérer le sens de la flèche.
2. - Dévisser l'insert Z5201/ Z5208,
- Tourner le corps pour amener le chiffre Z5202 en face du repère
3. - Revisser l'insert Z5201/ Z5208,
- Vérifier l'alignement

Datumsstempel

Date inserts

Dateurs

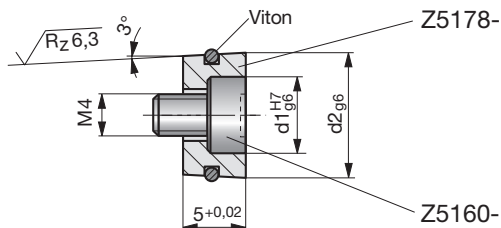

Z5163-	Mat.: 1.2842 ~60HRC	d2	b	a	d1	d2	b	a	d1
Z5163-d2-b-a		10	1 - 12	laufendes Jahr	6	14	1 - 12	laufendes Jahr	8
			13 - 22	current year	6		13 - 22	current year	8
			23 - 32	année courante	6		23 - 32	année courante	8
			33 - 42		6		33 - 42		8
			43 - 52		6		43 - 52		8

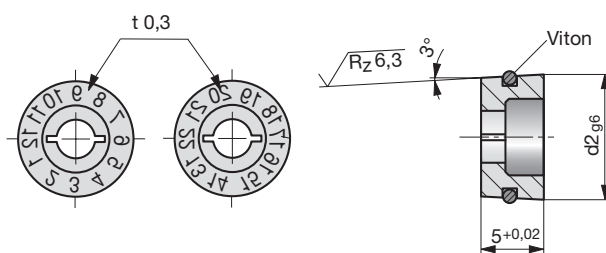

Z5178-	Mat.: 1.2842 ~60HRC	d2	b	d2	b
Z5178-d2-b		10	1 - 12	14	1 - 12
			13 - 22		13 - 22
			23 - 32		23 - 32
			33 - 42		33 - 42
			43 - 52		43 - 52

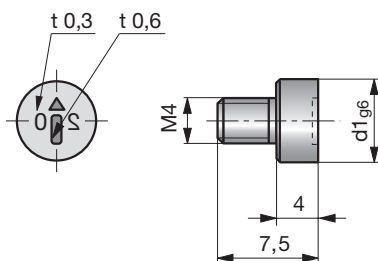

Z5160-	Mat.: 1.2842 ~60HRC	d1	a
Z5160-d1-a		6	laufendes Jahr
		8	current year
		10	année courante

Prägestempel

Embossing stamps

Tampons dateur avec gravure en relief

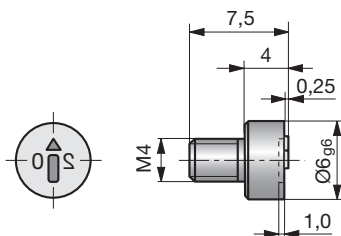
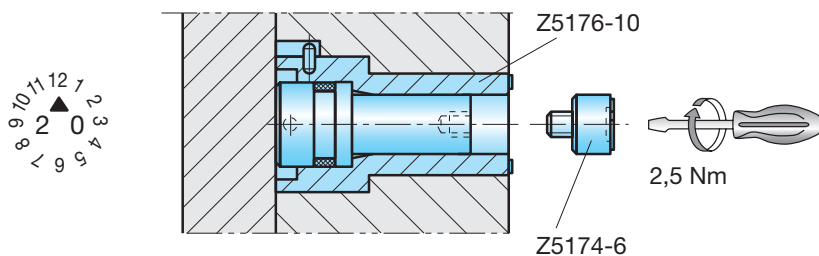

Z5174-6-

Mat.: 1.2379
~ 60HRC

a

laufendes Jahr
current year
année courante



Z5174-6-a

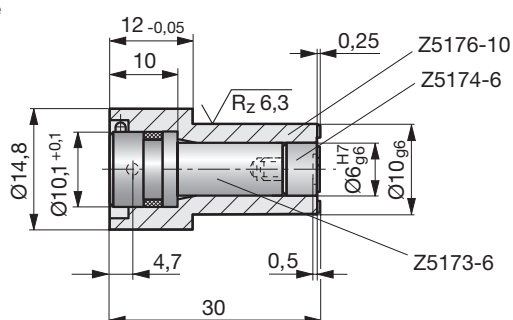
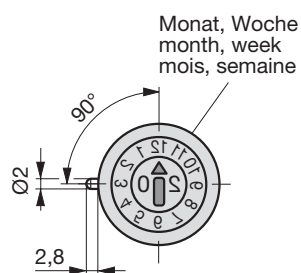

Z5177-10-

Mat.: 1.2162 / 1.2379
~ 60HRC

b

1 - 12
13 - 22
23 - 32
33 - 42
43 - 52

a

laufendes Jahr
current year
année courante



Z5177-10-b-a



Prägestempel

Embossing stamps

Tampons dateur avec gravure en relief

2

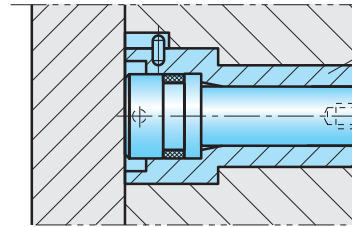

Z5207-10
Z5207-14

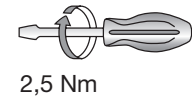

2,5 Nm

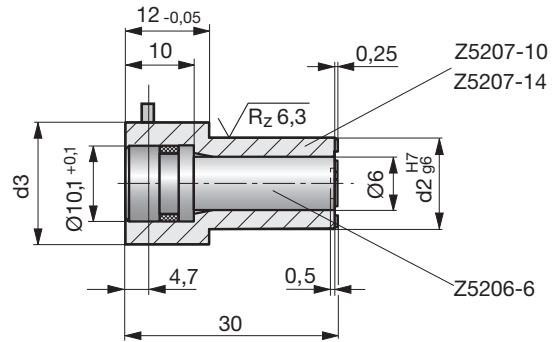
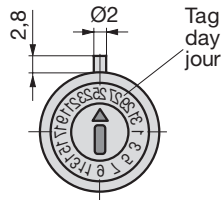

Z5205-

Mat.: 1.2379
~60HRC

d2

d3

10

14,8

14

18



Z5205-d2



Prägestempel

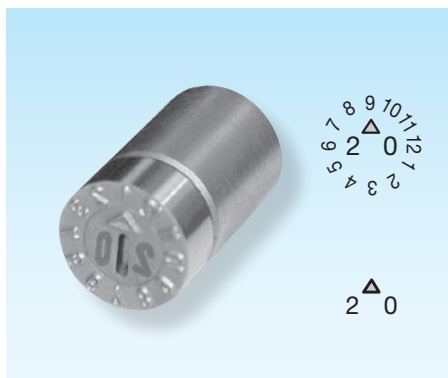

Embossing stamps

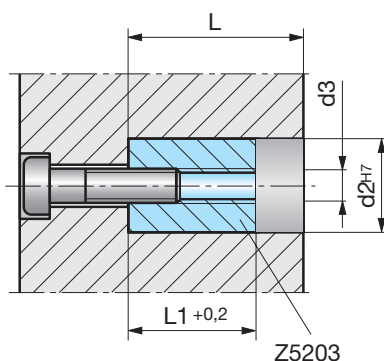

Tampons dateur avec gravure en relief

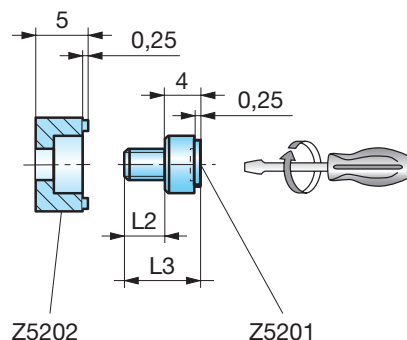

2

Montageanweisung



1. - Prägestempel komplett montieren,
- Pfeilrichtung markieren
2. - Innenteil Z5201/ Z5208 ausschrauben,
- Hülse Z5202 zur Markierung in Position drehen
3. - Innenteil Z5201/ Z5208 einschrauben,
- Position überprüfen

Installation instruction

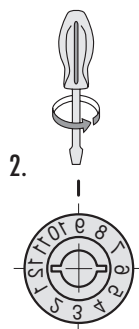

1. - Fully mount embossing stamp,
- Mark arrow direction
2. - Unscrew inner part Z5201/ Z5208,
- Rotate sleeve Z5202 into position for marking
3. - Srew in inner part Z5201/ Z5208,
- Check position

Instruction de montage



1. - Monter l'ensemble dateur,
- Repérer le sens de la flèche.
2. - Dévisser l'insert Z5201/ Z5208,
- Tourner le corps pour amener le chiffre Z5202 en face du repère
3. - Revisser l'insert Z5201/ Z5208,
- Vérifier l'alignement

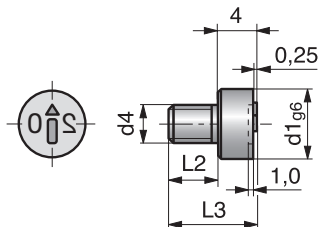

Z5201-

Mat.: 1.2379
~ 60HRC



Z5201-d1-a



d1

3,5

6

a

laufendes Jahr
current year
année courante

L2

4,5

6

L3

8,5

10

d4

M2,5

M4

Prägestempel

Embossing stamps

Tampons dateur avec gravure en relief

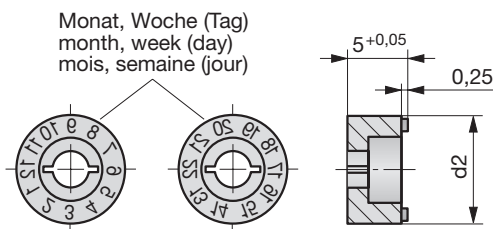

Z5202-	Mat.: 1.2379 ~ 60HRC	d2	b
Z5202-d2-b		6 / 10	1 - 12 13 - 22 23 - 32 33 - 42 43 - 52

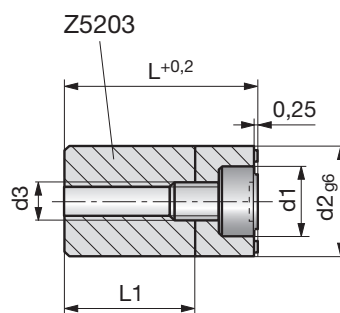

Z5200-	Mat.: 1.2162/1.2379 ~ 60HRC	d2	b	a	L	L1	d3
Z5200-d2-b-a		6	1 - 12 13 - 22 23 - 32 33 - 42 43 - 52	laufendes Jahr current year année courante	14	9	M3
		10	1 - 12 13 - 22 23 - 32 33 - 42 43 - 52		17	12	M4

Z5204-	Mat.: 1.2162/1.2379 ~ 60HRC	d2	b	L	L1	d3
Z5204-d2-b		6	1 - 12 13 - 22 23 - 32 33 - 42 43 - 52	14	9	M3
		10	1 - 12 13 - 22 23 - 32 33 - 42 43 - 52	17	12	M4

Endkontrollstempel

Final inspection stamp

Timbre du contrôle final

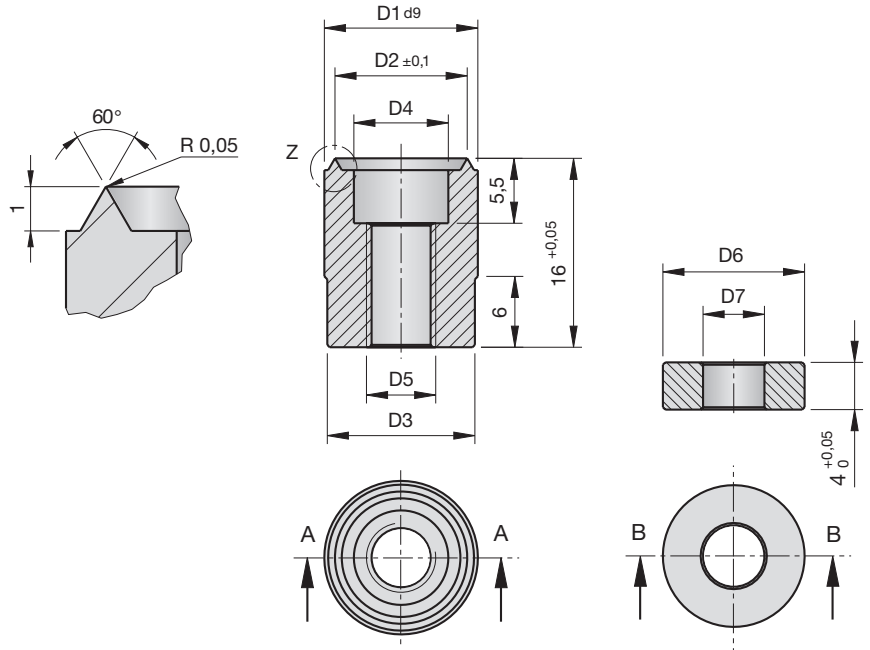
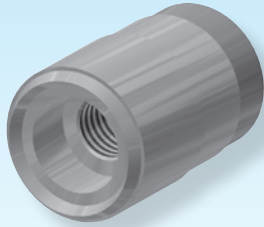

SN5270-

Mat.: ST
60 ±2HRC

SN5270-D1



D1	D2	D3	D4	D5	D6	D7	D8
10	8,0	9,5	6	M4	9	4,2	M3
13	11,2	12,5	8	M5	12	5,2	M4

